

KEEP FOR FUTURE REFERENCE



**P.O. Box 368 – 908 West Main
Laurel, MT USA 59044
phone 800-548-7341
phone 406-628-8231
fax 406-628-8354**

INSTRUCTIONS

International Version

MODEL NUMBERS: MRTALPCH611LDC,
MRTALPCH6HV11DC, MRTALPCH610DCO

SERIAL NUMBER: _____
(please see serial label and record number here)

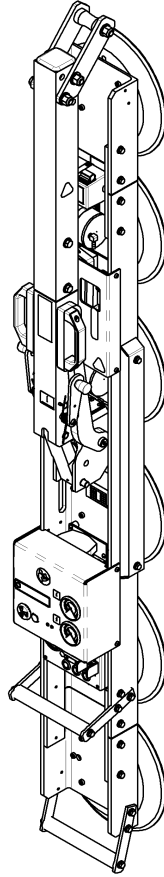

**MANUAL ROTATOR / TILTER
LOW-PROFILE, DC-VOLTAGE
WITH DUAL VACUUM SYSTEM
AND CHANNEL-STYLE PAD FRAME**



***READ ALL INSTRUCTIONS AND WARNINGS
BEFORE OPERATING THIS LIFTER***



DESIGNED FOR THE MATERIALS HANDLING PROFESSIONAL

TABLE OF CONTENTS

SPECIFICATIONS	3
WARNINGS	4
OPERATING FEATURES	5
ASSEMBLY	7
To SET UP THE LIFTER	7
To CHANGE THE PAD FRAME CONFIGURATION	8
To Connect/Disconnect Vacuum Hoses	8
To Install/Remove Pad Frame Extensions	9
INTENDED USE	10
LOAD CHARACTERISTICS	10
OPERATING ENVIRONMENT	11
DISPOSAL OF THE LIFTER	11
OPERATION	12
BEFORE USING THE LIFTER	12
Taking Safety Precautions	12
Performing Inspections and Tests	12
Confirming the Pad Frame Configuration	13
Preparing to Use the Optional Remote Control System	13
To APPLY THE PADS TO A LOAD	14
Positioning the Lifter on the Load	14
Powering up the Lifter	14
Sealing the Pads against the Load	14
Reading the Vacuum Gauges	15
Vacuum Level on Optimal Surfaces	15
Vacuum Level on Other Surfaces	

MAINTENANCE	21
INSPECTION SCHEDULE.....	21
Every-Lift Inspection	21
Frequent Inspection	21
Periodic Inspection.....	21
Infrequent Use.....	22
TESTING SCHEDULE.....	22
Operational Tests.....	22
Load Test	22
MAINTENANCE SCHEDULE.....	23
BATTERY TEST	23
BATTERY RECHARGE	23
BATTERY CHARGER TEST	24
VACUUM PAD MAINTENANCE.....	24
Friction Coefficient	24
Inspection	25
Cleaning	25
VACUUM TEST	26
REMOTE CONTROL SYSTEM TEST	26
AIR FILTER MAINTENANCE	27
Filter Function and Conditions Requiring Service	27
Filter Service Procedures	27
VACUUM PUMP MAINTENANCE – DYNAFLO DV1032102	28
Replacing the Diaphragm	28
Replacing the Gasket/Flap Valves.....	28
Replacing the Head Assembly	28
VACUUM PUMP MAINTENANCE – THOMAS 107CDC20	29
Replacing the Diaphragm	29
Replacing the Intake Valve Flapper	29
Replacing the Exhaust Valve Flapper and Head Gasket.....	29
VACUUM SWITCH ADJUSTMENT	30
Vacuum Switch Function	30
Conditions Requiring Readjustment.....	30
Adjustment Procedure	31
REPLACEMENT PARTS LIST	32
LIMITED WARRANTY.....	33

SPECIFICATIONS

Description:		Designed for use with a crane or other hoisting equipment, MRTALPCH6-DC lifters employ vacuum to hold a load for lifting, and they provide manual 180° rotation and manual 90° tilt movements for load manipulation.		
Model Number:		MRTALPCH611LDC	MRTALPCH6HV11DCO	MRTALPCH610DCO
Vacuum Pads: ¹		(Six of standard rubber, spring-mounted with 1/8" [3 mm] travel and #60 filter screen)		
		11" [28 cm] nom. diameter, lipped (Model G3370)	10" [25 cm] nom. diameter, lipped (Model HV11)	10" [25 cm] nom. diameter, concave (Model G0750)
Pad Spread:		(to outer edges)		
Minimum:		53¾" x 12" [1365 x 305 mm]	52¾" x 11" [1340 x 279 mm]	51¾" x 10" [1314 x 254 mm]
Maximum:		79¼" x 12" [2010 x 305 mm]	78¼" x 11" [1988 x 279 mm]	77¼" x 10" [1962 x 254 mm]
Load Capacity:		(rated at 16" Hg [-54 kPa] on clean, smooth, nonporous flat surfaces ²)		
Per-Pad:		184 lbs [83.5 kg]	150 lbs [68 kg]	150 lbs [68 kg]
Maximum w/4 pads:		700 lbs [320 kg]	600 lbs [270 kg]	600 lbs [270 kg]
Maximum w/6 pads:		1100 lbs [500 kg]	900 lbs [410 kg]	900 lbs [410 kg]
Lifter Weight:		125 lbs [57 kg]	131 lbs [60 kg]	118 lbs [54 kg]
Power Source:		12 volts DC, 10 amps (with Thomas pump) or 3 amps (with Dynaflo pump)		
Battery Capacity:		7 amp-hours		
Tilt Capability:		Manual, 90°, with mechanical advantage that minimizes operator effort and automatic latching in upright position		
Rotation Capability:		Manual, 180°, with automatic latching at each ¼ revolution (when desired)		
Vacuum Pump:		Diaphragm type, 1 SCFM [28 liters/minute] nominal airflow		
Dual Vacuum System:		2 vacuum system circuits allow the lifter to maintain the vacuum level in one circuit even if an unexpected vacuum loss occurs in the other one (eg, due to load breakage).		
Vacuum Reserve Tanks:		2 vacuum reservoirs help prevent immediate vacuum loss in case of power failure and extend battery life by reducing pump cycles required to maintain vacuum.		
Vacuum Gauges:		2 dial gauges indicate current vacuum level in positive inches of Hg and negative kPa.		
Vacuum Lift Light:		Green light is energized whenever vacuum is higher than the level required to lift the maximum load weight (16" [-54 kPa]).		
Low Vacuum Warning Buzzer:		Maximum Alarm Volume = 103 dBA at 2 ft [60 cm]. While the lifter is powered up, an audible alarm warns the operator whenever vacuum is not sufficient for lifting the maximum load weight.		
Options:		<i>Available</i> with Model EO8RC1 - Remote Control System. This option features a radio transmitter and receiver that can activate apply and release functions at distances up to 250 ft [76 m]. The system uses either a 310-320 or a 433-434 MHz signal, depending on requirements in your geographical location. See separate instructions about other options.		
Operating Elevation:		Maximum = 6000 ft [1828 m]		
Operating Temperatures:		32° to 104° F [0° to 40° C]		
Service Life:		This lifter is designed to have a service life of at least 20,000 lifting cycles, when used and maintained as intended. Vacuum pads, filter elements and other wear-out items are excluded; see MAINTENANCE and REPLACEMENT PARTS LIST for more information. For the DISPOSAL OF THE LIFTER after its service life, see INTENDED USE.		
ASME Standard BTH-1:		Design Category "B", Service Class "0" (see www.powrgrip.com for more information)		

!!-CE-!! Note: This symbol appears in the *INSTRUCTIONS* manual only when requirements of a CE Standard are *different* from requirements of other standards that also apply to this vacuum lifter. CE requirements are mandatory in geographical areas where CE Standards apply, but may be optional in other locations.

¹ Available with optional closed-cell foam rings for rough or textured surfaces (Model MRTALPCH6HV11FDCO), as well alternative rubber compounds for special applications (see REPLACEMENTS PARTS LIST).

² Load Capacity is based on a friction coefficient of 1; see MAINTENANCE: VACUUM PAD MAINTENANCE: Friction Coefficient for additional information.

WARNINGS



Powr-Grip is pleased to offer the most reliable vacuum lifters available. Despite the high degree of security provided by this product, certain precautions must be observed to protect the operator and others.



Always wear personal protective equipment that is appropriate for the material being handled. Follow trade association guidelines.

Always operate the lifter under conditions approved for its design (see INTENDED USE: OPERATING ENVIRONMENT).

Never operate a lifter that is damaged, malfunctioning, or missing parts.

Never operate a lifter if the sealing edge of any vacuum pad is cut or otherwise damaged.

Never remove or obscure warning labels.

Never operate a lifter if the Load Capacity or any warning appears to be missing or obscured.

Always make certain the contact surfaces of the load and all vacuum pads are clean prior to applying the pads (see MAINTENANCE: VACUUM PAD MAINTENANCE).

Never exceed the Load Capacity or attempt to lift loads the lifter is not designed for (see INTENDED USE: LOAD CHARACTERISTICS).

Never attempt to lift cracked or broken glass with this lifter.

Always position the vacuum pads correctly on the load prior to lifting (see OPERATION: TO APPLY THE PADS TO A LOAD).

Never lift a load when any vacuum indicator shows inadequate vacuum.

Never touch the vacuum release controls during a lift. This may result in loss of vacuum and release of the load.

Never allow people to ride on the lifter or the load being lifted.

Never lift a load higher than necessary or leave suspended loads unattended.

Never lift a load over people.

Always keep other personnel far enough away from the lifter to avoid injury in the event of an unexpected load release.

Always place the power control in the inactive position and, when possible, disconnect the power source before opening any enclosure on the lifter. (Only applicable to powered lifters)

Always remember that modifications to the lifter may compromise its safety. Wood's Powr-Grip cannot be responsible for the safety of a lifter that has been modified by the customer. For consultation, contact Wood's Powr-Grip (see LIMITED WARRANTY).

Never disengage both the rotation latch and the tilt latch at the same time.

If the lifter is equipped with a Remote Control System, **never** operate the lifter remotely unless there is clear communication about intended actions (eg, releasing load) with all personnel near the lift. In addition, the operator must visually verify the status of the lifter and load prior to remote operations.

OPERATING FEATURES

Note: Components featured in the following instructions for assembling, operating or maintaining the vacuum lifter are underlined on their first appearance in each section.

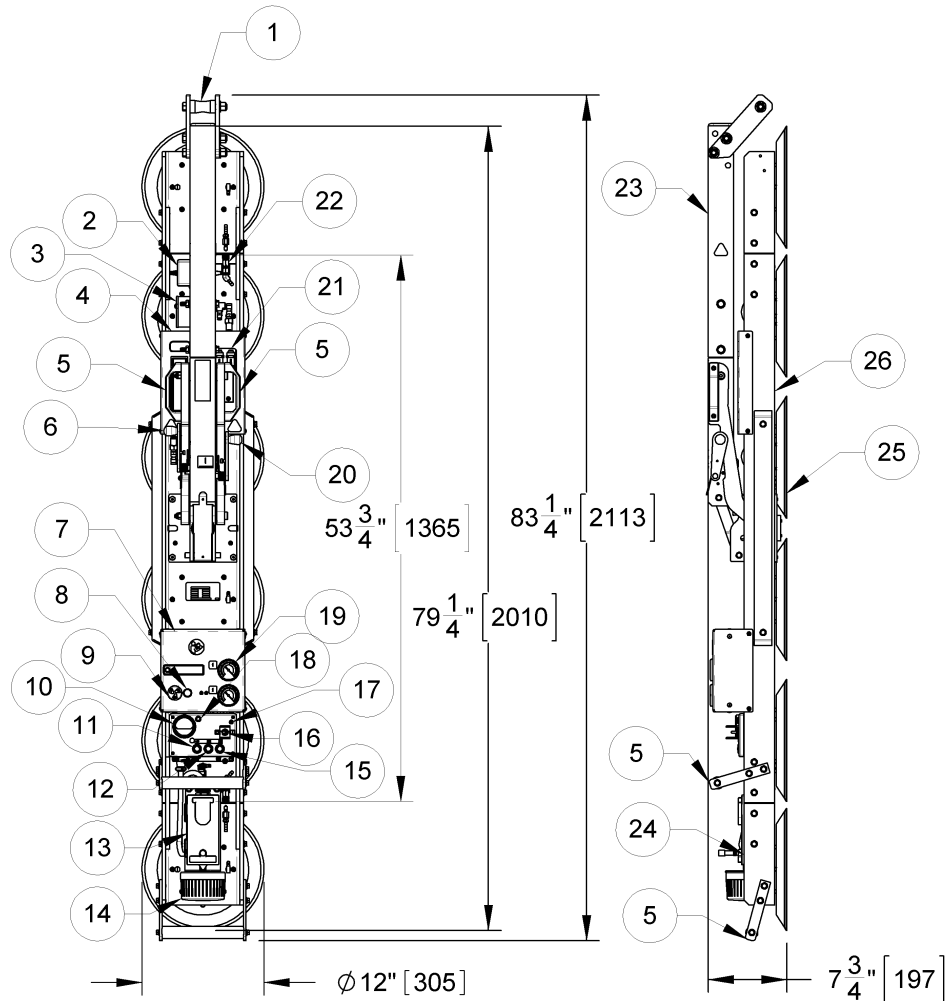

Standard MRTALPCH611LDC shown with Remote Control System option.

- | | | | | | |
|---|---------------------------|----|------------------------------|----|------------------------|
| 1 | LIFT SPOOL | 10 | BATTERY GAUGE | 19 | VACUUM GAUGE |
| 2 | BATTERY CHARGER | 11 | ENABLE BUTTON | 20 | ROTATION RELEASE LEVER |
| 3 | VACUUM RESERVE TANK | 12 | APPLY BUTTON | 21 | Cover for AIR FILTERS |
| 4 | Cover for BATTERY | 13 | RADIO RECEIVER (optional) | 22 | QUICK CONNECTOR |
| 5 | CONTROL HANDLES | 14 | STROBE LIGHT (optional) | 23 | LIFT BAR |
| 6 | TILT RELEASE LEVER | 15 | VACUUM RELEASE BUTTON | 24 | PAD FRAME EXTENSION |
| 7 | Cover for VACUUM PUMP | 16 | POWER SWITCH | 25 | VACUUM PAD |
| 8 | VACUUM LIFT LIGHT | 17 | Enclosure with VACUUM SWITCH | 26 | PAD FRAME |
| 9 | LOW VACUUM WARNING BUZZER | 18 | BATTERY TEST BUTTON | | |

- 1 TRANSMISSION INDICATOR LIGHT
- 2 TRANSMITTER POWER/ENABLE BUTTON
- 3 RELEASE BUTTONS
- 4 APPLY BUTTONS
- 5 EMERGENCY TRANSMITTER DISCONNECT

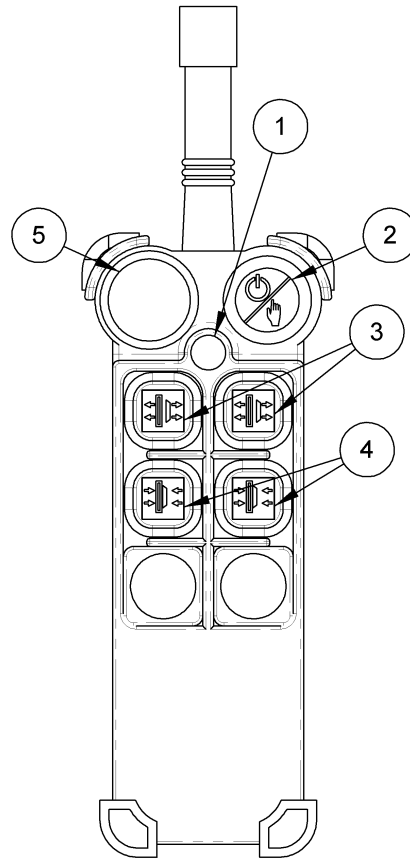

OPTIONAL RADIO TRANSMITTER

ASSEMBLY

TO SET UP THE LIFTER

- 1) Open the shipping container and remove all materials for restraining or protecting the vacuum lifter. Save the container for use whenever the lifter is transported.
- 2) If necessary, assemble the lifter's lift bar as follows: One segment of the lift bar can be removed, to reduce overall lifter dimensions for shipping. If so, orient the removable segment (1) as shown in the illustration, and slide it over the other segment until the bolt holes align. Reinstall the bolts and all associated hardware (2); then tighten both bolts securely.
- 3) Position the lifter's lift spool as follows: The adjustable lift spool assembly provides 3 different lift points (see illustration), in order to optimize the lifter's hang angle and/or its overall height for the intended use.³ To change the lift spool position, remove the retaining bolt (3) and, if necessary, loosen the pivot bolt (4). Next pivot the lift spool assembly until the bolt holes align for the desired spool position. Then reinstall the retaining bolt and all associated hardware. Tighten both bolts securely.
- 4) Suspend the lifter from a crane as follows: Select hoisting equipment (crane and hoist, when applicable) rated to carry the maximum load weight plus the lifter weight (see SPECIFICATIONS: Maximum Load Capacity and Lifter Weight).

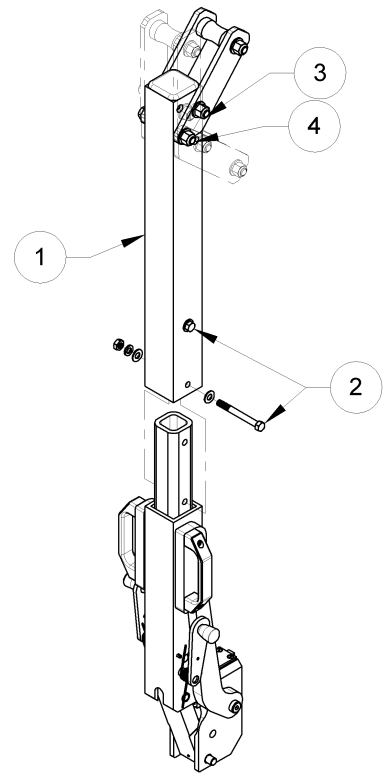

Note: Any application of the lifter must conform to all statutory or regulatory standards that relate to the hoisting equipment when used in its geographical location (eg, relevant OSHA standards in the USA).

Disengage the tilt latch (see OPERATION: TO TILT THE LOAD) and raise the lift bar to a vertical orientation. Then attach the hoisting equipment hook to the lift spool.

⚠ WARNING: Hoisting equipment hook must be fitted with restraining latch to prevent lift spool from slipping off under any circumstances.

Note: Some hoisting equipment hooks could interfere with an upright load that extends beyond the lifter's pad frame. If the load would contact the hook during lifter operation, the operator must prevent this by attaching a sling (or other rigging that does not interfere with the load) between the hook and the lift spool.

⚠ WARNING: Any sling used must be rated to carry maximum load weight plus lifter weight.

³ When the pad frame is used in the vertical orientation (see illustration in OPERATING FEATURES), placing the lift spool in the lowest position creates interference with the pad frame extension. To avoid this problem, place the lift spool in one of the other two positions or remove the pad frame extensions (see TO CHANGE THE PAD FRAME CONFIGURATION to follow).

Use the hoisting equipment to raise the lifter out of the shipping container. Be careful to avoid damaging any vacuum pads.

- 5) Arrange the pad frame in the configuration that will provide optimal support of the load while lifting (see TO CHANGE THE PAD FRAME CONFIGURATION to follow). Remove the pad covers and save them for use whenever the lifter is stored.
- 6) Connect the electrical connectors uniting the battery to the battery charger and the vacuum generating system. Now the lifter is operational.
- 7) Perform Operational and Load Tests for the lifter as directed in MAINTENANCE: TESTING SCHEDULE. If the lifter is equipped with a Remote Control System, also perform the REMOTE CONTROL SYSTEM TEST (see MAINTENANCE).

TO CHANGE THE PAD FRAME CONFIGURATION

The lifter offers two pad frame configurations to accommodate different load dimensions and weights (see SPECIFICATIONS: Pad Spread and Load Capacity). Select the configuration that provides optimal support across the load surface and minimizes load overhang (see OPERATION: BEFORE USING THE LIFTER). To support longer, heavier loads (see Maximum Pad Spread and Maximum Load Capacity in SPECIFICATIONS), both pad frame extensions must be installed on the pad frame and the vacuum hoses must be connected to the vacuum pads located on the extensions.

⚠ WARNING: *Removing any extension or disconnecting the corresponding vacuum pad reduces load capacity of lifter.*

To support smaller dimensions and weights, the pad frame extensions may be removed, and the corresponding vacuum hoses may be disconnected, ***provided that the lifter still has sufficient capacity to support the load in question*** (see INTENDED USE: LOAD CHARACTERISTICS). The Maximum Load Capacity is reduced when the pad frame extensions are removed. Always assemble the pad frame with both extensions installed or both removed, to keep the lifter balanced.

To Connect/Disconnect Vacuum Hoses

The vacuum hose for the vacuum pad on each pad frame extension is connected to or disconnected from the vacuum system by means of a quick connector. To connect the vacuum hose, push the male and female ends of the connector together until they lock. To disconnect the vacuum hose, move the release ring on the female end away from the male end until the connector separates.

⚠ WARNING: *Make sure vacuum hoses are coiled or routed to avoid damage during rotation or tilt.*

Make sure all vacuum hoses are secure and routed to avoid being punctured, pinched, kinked, entangled, abraded or otherwise damaged while the lifter is in operation.

Note: Whenever a quick connector is disconnected, the corresponding vacuum pad does not contribute to the load capacity, whether or not the extension is mounted on the pad frame.

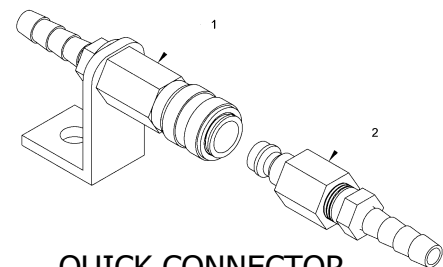

QUICK CONNECTOR

- 1 FEMALE END
- 2 MALE END

To Install/Remove Pad Frame Extensions

- 1) Set the lifter with the vacuum pads facing downward on a clean, smooth, flat surface.
- 2) Insert the tabs extending from one pad frame extension between the rails of the pad frame. If the tabs do not fit between the rails, you may loosen the bolts that connect the tabs to the extension. Make sure that the vacuum pads on the extension and on the pad frame are contacting the same surface, to ensure that all the pads are aligned in the same plane.

Note: The pad frame extension that is equipped with a control handle should be installed on the lower end of the pad frame (ie, when oriented vertically).
- 3) Align the bolt holes in the pad frame extension with the bolt holes in the pad frame.
- 4) Secure the pad frame extension in the pad frame by installing the bolts supplied and tightening all bolts securely.
- 5) Connect the vacuum hose to the vacuum pad on the pad frame extension as directed in the preceding section, To Connect/Disconnect Vacuum Hoses.
- 6) Repeat steps 1-5 to install the other pad frame extension.
- 7) To remove pad frame extensions, reverse this procedure. Store removed extensions in a clean, dry location, to protect them from environmental exposure. Use the pad covers supplied to keep the vacuum pads clean.

INTENDED USE

LOAD CHARACTERISTICS

 **WARNING:** *This lifter is NOT intended for lifting hazardous materials, such as explosives or radioactive substances.*

The operator must verify that the lifter is intended to handle each load, in accordance with the following requirements:

- The load must not exceed the maximum allowable weight specified under Load Capacity (see SPECIFICATIONS).
- The load must be a single piece of nonporous or semiporous material with a flat and relatively smooth contact surface.⁴ To determine whether the load is too porous or rough, perform the test under Vacuum Level on Other Surfaces (see OPERATION: TO APPLY THE PADS TO A LOAD).
- The load's contact surface must be suitable for obtaining a friction coefficient of 1 with the lifter's vacuum pads (see MAINTENANCE: VACUUM PAD MAINTENANCE: Friction Coefficient), as verified by a friction test. If necessary, contact Wood's Powr-Grip for help in conducting a friction test.
- In order to avoid damaging the vacuum pads, the load's surface temperature must not exceed the allowable Operating Temperatures (see SPECIFICATIONS). However, if such an application cannot be avoided, Wood's Powr-Grip does offer a heat-resistant rubber compound and other solutions which may enable you to lift loads with higher surface temperatures. Contact Wood's Powr-Grip or an authorized dealer for more information.
- While the *minimum* length and width of the load are determined by the Pad Spread (see SPECIFICATIONS), the *maximum* length and width are determined by the allowable overhang, or the amount of load material that can extend sideways beyond the vacuum pads without breaking or otherwise being damaged.

The allowable overhang depends on the kind of load material being lifted, the thickness of the material, and the angle at which it is handled (if any). Since materials such as glass, stone or sheet metal each have different physical properties, the allowable overhang must be evaluated separately for each type of load. If necessary, contact Wood's Powr-Grip or an authorized dealer for help in determining the recommended overhang in a specific situation.

- In order to maintain load stability in the upright position, the maximum allowable thickness of loads is 1½" [3.8 cm] at the maximum weight (see SPECIFICATIONS: Load Capacity).⁵ This allowance assumes that the load is centered correctly on the lifter's pad frame (see OPERATION: TO APPLY THE PADS TO A LOAD: Positioning the Lifter on the Load) and that no other forces, such as wind pressure, are at work on the load. Either of these circumstances could reduce the allowable load thickness.

⁴ Lifters that feature concave vacuum pads can also attach to some kinds of curved loads. Since curvature affects the lifting capacity, contact Wood's Powr-Grip for help in determining the Load Capacity for a particular curved load.

⁵ This allowance does **not** account for the use of Pad Spacers (option CM3PE2). **WARNING: Pad Spacers can reduce load stability in the upright position and, in some cases, the allowable thickness of loads.**

Conversely, allowable thickness increases as load weight decreases. In addition, an operator may be able to manually counteract the tendency of unstable loads to tilt out of the upright position, provided that the operator maintains control of the load at all times (see OPERATION: TO LIFT AND MOVE THE LOAD: About the Tilt Linkage and TO TILT THE LOAD). If necessary, contact Wood's Powr-Grip for help in determining the maximum thickness permitted when handling any specific load.

Note: Vacuum pads can stain or deform load surfaces with light colors or soft coatings. The operator should test such surfaces for detrimental effects before using the lifter on them.

OPERATING ENVIRONMENT

The operator must determine whether the lifter is intended to be used in each work environment, in accordance with the following restrictions:

 **WARNING: Never use lifter in dangerous environments.**

- This lifter is not intended for use in any environment that is inherently dangerous to the operator or likely to compromise the lifter's ability to function. Environments containing explosives, caustic chemicals and other dangerous substances must be avoided when using the lifter.
- The lifter's work environment is limited by the Operating Elevation and Operating Temperatures indicated in SPECIFICATIONS.
- The lifter's work environment must be free of metal particles or any other contaminants that could damage lifter components through airborne contact or any other means of transmission in the environment. If such contaminants cause a vacuum pump failure, they could result in a load release and possible injury to the operator or others nearby.

 **WARNING: Environmental contaminants could result in vacuum pump failure.**

- Using the lifter in wet environments may require the operator to take special precautions: Moisture on contact surfaces of the load or vacuum pads diminishes the lifter's slip resistance, thereby reducing the lifting capacity (see MAINTENANCE: VACUUM PAD MAINTENANCE: Friction Coefficient).

 **WARNING: Moisture reduces slip resistance of vacuum pads.**

Although the lifter's exterior surfaces can tolerate some exposure to water vapor, they are not designed to be water-tight. Submerging the lifter or using it in rain may damage lifter components; these and similar conditions must be avoided.

- If the lifter is equipped with a Remote Control System, the work environment must be suitable for using it, as verified by the REMOTE CONTROL SYSTEM TEST (see MAINTENANCE).

DISPOSAL OF THE LIFTER

After the vacuum lifter has reached the end of its service life, you must dispose of the lifter in compliance with all local codes and regulatory standards that are relevant for the geographical region.

Note: This lifter is equipped with a battery, which may be subject to special disposal regulations.

OPERATION

BEFORE USING THE LIFTER

The operator must determine whether the lifter is capable of performing each intended task, in accordance with the SPECIFICATIONS and INTENDED USE sections of this *INSTRUCTIONS* manual. In addition, all of the following preparations must be completed prior to lifting any load.

Taking Safety Precautions

The operator must be trained in all relevant industry and regulatory standards for the operation of the vacuum lifter in its geographical location (eg, ASME B30.20 in the USA).

The operator must read and understand this *INSTRUCTIONS* manual, including all **WARNINGS**, before using the lifter. If necessary, contact Wood's Powr-Grip or an authorized dealer for assistance.

⚠ WARNING: Always wear appropriate personal protective equipment.

The operator must wear any personal protective equipment and take any other precautions required to handle the load safely. Consult appropriate trade association guidelines to determine what precautions are necessary for each type of load material.

Performing Inspections and Tests

⚠ WARNING: Always check battery energy before using lifter.
(See MAINTENANCE: BATTERY TEST)

Perform all inspections and tests required by the INSPECTION and TESTING SCHEDULES (see MAINTENANCE). In addition, if the lifter has been in storage, always conduct a VACUUM TEST before placing it in service (see MAINTENANCE).

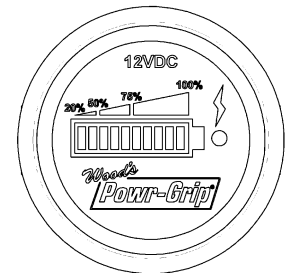

⚠ WARNING: Make sure alarm is clearly audible over ambient noise at operator position.

The volume of the alarm may be adjusted by rotating the shutter of the low vacuum warning buzzer. Make sure the alarm is loud enough to be heard over any other noise that may be present while the lifter is in use. In addition, the alarm must be clearly audible at the maximum distance the operator may be from the lifter, as well as through any barriers or obstructions between the operator and the lifter. In order to be considered clearly audible, **the alarm volume must exceed ambient noise by at least 15 dBA at the operator position.**⁶ Since the Maximum Alarm Volume is 103 dBA, ambient noise must not exceed 88 dBA under any circumstances. Furthermore, if ambient noise measures 88 dBA, the alarm volume must be set to maximum and the operator must remain within 2 ft [60 cm] of the warning buzzer, in order for it to be effective.

⁶ Consult CE Standard EN 457 for alternative ways to determine whether the alarm is clearly audible to operators.

CAUTION: *Examine each air filter regularly, and empty when necessary.*

Two air filters help protect the vacuum generating system from contaminants. However, the lifter is not intended for use on wet load surfaces because the filters would not prevent liquid from entering the vacuum system. The operator must examine each filter regularly and remove any liquid or other contaminants found inside (see MAINTENANCE: AIR FILTER MAINTENANCE). To access the air filters, remove the cover indicated in OPERATING FEATURES.

Confirming the Pad Frame Configuration

 **WARNING:** *Load capacity of lifter can vary, depending on pad frame configuration.*

Make sure the pad frame has been assembled in the configuration that will provide optimal support of the load while lifting (see ASSEMBLY: TO CHANGE THE PAD FRAME CONFIGURATION). The pad frame configuration selected must be appropriate, both for the weight and for the dimensions of the load in question.

Preparing to Use the Optional Remote Control System

If the lifter is equipped with a Remote Control System, the operator can engage the lifter's apply and release functions at distances up to 250 ft [76 m], provided there is a direct and clear view of the lifter and its status indicators from the operator location (see MAINTENANCE: REMOTE CONTROL SYSTEM TEST). When lifting a load from a remote location, the operator must monitor the lifter at all times to make sure that it is functioning as intended.⁷ In addition, the operator must exercise special care to ensure that the load is landed and supported correctly before releasing the load (see TO RELEASE THE PADS FROM THE LOAD to follow).

The radio transmitter is also equipped with an emergency transmitter disconnect that prevents the transmitter from sending any transmission. This button should not need to be used, but may have to be reset if accidentally engaged. To reset, twist the button clockwise while allowing it to spring outward to its normal position.

⁷ The Remote Control System is designed with safeguards to prevent multiple lifters from responding until a clear transmission is received. Nevertheless, radio controlled lifters should be tested to ensure that each transmitter controls only one lifter. The buttons located on the lifter function regardless of any radio transmissions in the vicinity.

TO APPLY THE PADS TO A LOAD

Positioning the Lifter on the Load

Make certain that the contact surfaces of the load and all vacuum pads are free of any contaminants that could prevent the pads from sealing against the load (see MAINTENANCE: VACUUM PAD MAINTENANCE).

Center the lifter's pad frame to within 2" [5 cm] of the load center, since off-center loading can cause the load to rotate or tilt unexpectedly (see TO ROTATE THE LOAD EDGEWISE or TO TILT THE LOAD to follow), and it may also damage the lifter.⁸ Make sure that all vacuum pads will fit entirely on the load's contact surface (see SPECIFICATIONS: Pad Spread) and that they will be loaded evenly while lifting (see SPECIFICATIONS: Per-Pad Load Capacity). Then apply the lifter to the load so that all pads are touching the contact surface.

Powering up the Lifter

Place the lifter's power switch in the ON () position.⁹ The blue power light remains illuminated while the lifter is powered up. Keep the power switch in the ON position while lifting a load. Any power interruption during a lift could result in the release of a load and possible injury to the operator or others (see TO LIFT AND MOVE THE LOAD: In Case of Power Failure to follow).

 **WARNING: Never turn power off while lifting.**

If the lifter is equipped with a Remote Control System, press the transmitter power/enable button and hold it briefly to activate the radio transmitter.¹⁰ This button is also used to activate the enable function (see TO RELEASE THE PADS FROM THE LOAD to follow).

Note: If the transmitter is activated, the transmission indicator light flashes green when any button on the transmitter is pressed and held; if the transmitter is not activated, the indicator light flashes red (see BEFORE USING THE LIFTER: Preparing to Use the Optional Remote Control System preceding).

Sealing the Pads against the Load

Firm pressure at the center of the lifter helps the vacuum pads begin to seal against the load. Press an apply button on the lifter or the optional radio transmitter to make sure the apply function is activated. This energizes the vacuum pump, causing air to be drawn at the pads immediately. The low vacuum warning buzzer also sounds an alarm until the lifter attains sufficient vacuum to lift the maximum load weight (see TO LIFT AND MOVE THE LOAD: Interpreting the Warning Buzzer and Lift Light to follow). The lifter must remain in the apply mode throughout the entire lift.

⁸ The lifter is designed to handle the maximum load weight (see SPECIFICATIONS: Maximum Load Capacity) when the load's center of gravity is positioned within 2" [5 cm] of the pad frame's center point. Occasional loading deviations are permissible, provided that the operator can maintain control of the load at all times and that the load weight is low enough to avoid damaging the lifter.

⁹ When the operator powers up the lifter, either the stand-by function or the apply function is automatically activated, depending on which was used last.

¹⁰ The radio transmitter turns off automatically, after a period of inactivity. The operator can also operate the lifter without using the radio transmitter, if desired.

 **WARNING: Keep apply function activated throughout lift.**

Note: If a vacuum pad has been lying against a hard object (as during shipping), it may be slightly distorted. Although initially it may be difficult to apply the pad to a load, this condition should correct itself with continued use.

Reading the Vacuum Gauges

The lifter is equipped with 2 vacuum gauges, which indicate the current vacuum level in each circuit of the lifter's vacuum system. The *green* range indicates vacuum levels sufficient for lifting the maximum load weight, whereas the *red* range indicates vacuum levels that are **not** sufficient for lifting the maximum load weight. Both gauge needles should show a sudden surge in vacuum as the vacuum pads seal against the load. If it takes more than 5 seconds for the vacuum level to reach 5" Hg [-17 kPa] on either vacuum gauge, press on any pad that has not yet sealed.

Vacuum Level on Optimal Surfaces

When the lifter is attached to clean, smooth, nonporous load surfaces, it should be able to maintain a vacuum level in the green range on both vacuum gauges, except when used at high elevations (see SPECIFICATIONS: Operating Elevation). If not, make sure the vacuum switch is adjusted correctly (see MAINTENANCE: VACUUM SWITCH ADJUSTMENT). If the vacuum switch cannot be adjusted to maintain a vacuum of 16" Hg [-54 kPa], perform the VACUUM TEST (see MAINTENANCE) to determine whether there is a deficiency in the vacuum generating system.

Vacuum Level on Other Surfaces

When the lifter is attached to contaminated, rough or porous load surfaces, it may not be able to maintain a vacuum level in the green range on both vacuum gauges, due to leakage in the seal between the vacuum pads and the load surface.¹¹ In the case of contamination, thoroughly clean the contact surfaces of the load and the vacuum pads (see MAINTENANCE: VACUUM PAD MAINTENANCE: Cleaning), and reapply the lifter to the load. If the load has rough or porous surfaces, **the operator must conduct a test to determine whether the lifter is designed to lift the load**, as follows:

- 1) Make sure the lifter's vacuum generating system is functioning correctly (see MAINTENANCE: VACUUM TEST).
- 2) Apply the vacuum pads to the load as previously directed.
- 3) After the vacuum pump stops running, place the lifter's power switch in the OFF () position.
- 4) Raise the load a minimal distance, to assure that it is supported by the lifter.
- 5) Monitor both vacuum gauges while the load is suspended for 5 minutes: **The lifter must maintain a minimum vacuum level of 10" Hg [-34 kPa] during this time.** If not, the load does not possess the characteristics required for using this lifter.¹²

¹¹ Contaminated loads can also cause the vacuum pump to run frequently or continuously. Since excessive pumping quickly reduces battery energy, the operator should clean the load when possible, to minimize pumping.

¹² Certain load materials are too rough or porous to allow the lifter to form a seal which can be maintained for 5 minutes without power. However, in geographical locations where CE Standards do not apply, it may be possible to use the lifter to lift such loads. Contact Wood's Powr-Grip for more information.

TO LIFT AND MOVE THE LOAD

Positioning the Lift Bar

⚠ WARNING: *Lift bar must be oriented vertically to lift load.*

Never lift the load from a flat position with the lift bar latched parallel to the load. Always disengage the tilt latch (see TO TILT THE LOAD to follow) and raise the lift bar to a vertical orientation before attempting to lift.

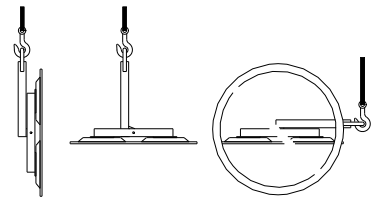

Interpreting the Warning Buzzer and Lift Light

A lifter's Load Capacity is rated at a vacuum level of 16" Hg [-54 kPa] (see SPECIFICATIONS). After the lifter has attained this level, the vacuum pump and the low vacuum warning buzzer turn *off* automatically, to conserve battery energy. At the same time, the green vacuum lift light turns *on*, to signal that the lifter is ready to lift the maximum load weight.

⚠ WARNING: *Never attempt to lift load unless green lift light is illuminated.*

Do not attempt to lift the load unless the lift light is illuminated; such an attempt could result in a load release and possible injury to the operator.

Monitoring Vacuum Indicators

The vacuum lift light and both vacuum gauges must remain completely visible to the operator, so that they can be monitored throughout the entire lift.

⚠ WARNING: *Vacuum indicators must be visible to operator throughout entire lift.*

If the vacuum system experiences leakage while the lifter is attached to the load, the vacuum pump turns *on* automatically, as required to maintain sufficient vacuum for lifting the maximum load weight. In addition, the lift light turns *off* while the pump is running, to signal the reduction in vacuum to the operator.

If the pump turns on and lift light turns off while you are lifting a load, make sure both vacuum gauges show a vacuum level of 16" Hg [-54 kPa] or higher. If not, move away and stay clear of the load until it can be lowered to the ground or a stable support.

⚠ WARNING: *Stay clear of any suspended load while vacuum level is lower than 16" Hg [-54 kPa].*

Discontinue lifter use until the cause of the vacuum loss can be determined. If the pump runs at intervals of ten minutes or less while the lifter is attached to clean, smooth, nonporous materials, the leakage is likely to be in the vacuum system. In this event, perform the VACUUM TEST (see MAINTENANCE) and inspect the vacuum pads for damage (see MAINTENANCE: VACUUM PAD MAINTENANCE: Inspection). If the vacuum loss cannot be remedied immediately, perform inspection and maintenance as needed to identify and correct any deficiency before resuming normal operation of the lifter.

Monitoring the Low Vacuum Warning Buzzer

Using the low vacuum warning buzzer requires minimal interaction from the operator. The warning buzzer sounds an alarm until the lifter attains sufficient vacuum to lift the maximum load weight (see SPECIFICATIONS: Load Capacity). After the lifter has attained this vacuum level, the alarm stops sounding, to indicate that the lifter is ready to lift the load.

 **WARNING: Never attempt to lift load while alarm is sounding.**

Do not attempt to lift the load while the alarm is sounding; such an attempt could result in a load release and possible injury to the operator.

If the vacuum system experiences leakage while the lifter is attached to the load, the vacuum pump turns on automatically, as required to maintain sufficient vacuum. The alarm also sounds while the pump is running, to signal the reduction in vacuum to the operator. If the alarm sounds while you are lifting a load, make sure the vacuum gauge shows a vacuum level of 16" Hg [-54 kPa] or higher. If not, immediately move away and stay clear of the load until it can be lowered to the ground or a stable support.

 **WARNING: Stay clear of any suspended load while alarm is sounding.**

Discontinue lifter use until the cause of the vacuum loss can be determined. Using the lifter on contaminated, rough or porous surfaces may result in a vacuum loss, due to leakage between the vacuum pads and the load. Since the alarm may sound in such circumstances, consult the section TO APPLY THE PADS TO A LOAD: Vacuum Level on Other Surfaces to determine whether the lifter can be used to lift the load. If the vacuum loss is due to any other cause, perform inspection and maintenance as needed to identify and correct any deficiency before resuming normal operation of the lifter.

Controlling the Lifter and Load

When the vacuum indicators show that the lifter is ready, use the hoisting equipment to raise the lifter and load as needed to clear any obstacles in their path. Use the control handles to keep the lifter and load in the desired orientation while they are suspended from the crane. Once sufficient clearance is established, the load can be rotated or tilted as desired (see TO ROTATE THE LOAD EDGEWISE or TO TILT THE LOAD to follow).

In Case of Power Failure

The lifter is equipped with 2 vacuum reserve tanks, designed to maintain vacuum temporarily in case of a power failure (ie, in battery).

 **WARNING: Stay clear of any suspended load in the event of a power failure.**

Although the lifter is designed to support the load for at least 5 minutes without power, this depends on many factors, including the condition of the load and the lifter's vacuum system (see INTENDED USE: LOAD CHARACTERISTICS and MAINTENANCE: VACUUM PAD MAINTENANCE, VACUUM TEST). If a power failure occurs, keep all personnel clear of the suspended load until it can safely be placed on the ground or a stable support. Correct any deficiency before resuming normal operation of the lifter.

TO ROTATE THE LOAD EDGEWISE

 **WARNING:** *Never disengage both the rotation latch and the tilt latch at the same time.*

This lifter is not designed for rotation and tilt functions to be used at the same time. Disengaging the rotation and tilt latches simultaneously could cause uncontrolled and unpredictable load movement, potentially resulting in load damage or injury to the operator.

CAUTION: *Rotation function only works when pad frame is latched in vertical orientation.*

Make sure the pad frame is latched in the vertical position of the tilt range (see TO TILT THE LOAD to follow), as shown in the OPERATING FEATURES illustration, because the rotation function is not designed to work in any other position.

 **WARNING:** *Make sure load is positioned correctly on lifter (see To APPLY); unbalanced loads may rotate unexpectedly when latch is disengaged.*

Remember that the load is longer in its diagonal dimensions than in its side dimensions. Make sure there is sufficient clearance for the load to rotate without contacting the operator or any nearby objects. Maintain a firm grip on one control handle (located on pad frame) to keep the load under control at all times. Pull the rotation release lever to disengage the rotation latch, and rotate the load to the desired position. To stop the load's motion automatically at each quarter turn, simply let go of the rotation release lever immediately after initiating the rotation, so that the rotation latch engages at the next stop. Whenever rotation is not required, keep the rotation latch engaged, to prevent accidental damage to the load and possible injury to the operator.

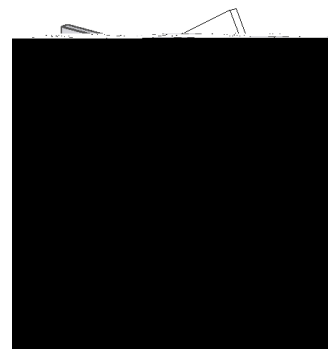

TO TILT THE LOAD

⚠ WARNING: *Never disengage both the rotation latch and the tilt latch at the same time.*

This lifter is not designed for rotation and tilt functions to be used at the same time. Disengaging the rotation and tilt latches simultaneously could cause uncontrolled and unpredictable load movement, potentially resulting in load damage or injury to the operator.

CAUTION: *Tilt function only works when pad frame is latched in center position of rotation range.*

Make sure the pad frame is latched in the center position of the rotation range (see TO ROTATE THE LOAD EDGEWISE preceding), as shown in the OPERATING FEATURES illustration, because the tilt function is not designed to work in any other position.

⚠ WARNING: *Make sure load is positioned correctly on lifter (see TO APPLY); unbalanced loads may tilt unexpectedly when latch is disengaged.*

⚠ WARNING: *Always keep hands and fingers away from bars of tilt linkage.*

Remember that the load requires more vertical space when tilted to the upright position, as well as more horizontal space when tilted to the flat position. Make sure there is sufficient clearance for the load to tilt without contacting the operator or any nearby objects. Maintain a firm grip on one control handle (located on pad frame) to keep the load under control at all times. If the pad frame is latched in the vertical position, pull the tilt release lever to disengage the tilt latch. Lift upward or press downward on the control handle to tilt the load as desired. If load size permits, maintain control with the handle throughout the tilt. For loads with overhang, it may be necessary to release the control handle as the load approaches the flat position. If so, keep the load under control using hand cups or other appropriate means. The pad frame automatically latches in place when it returns to the vertical position.

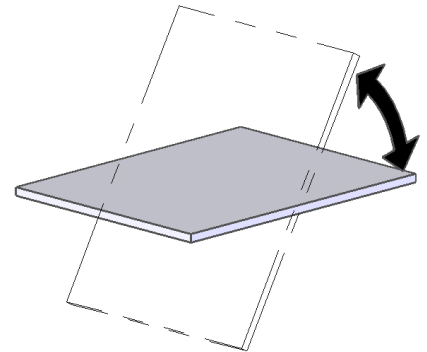

TO RELEASE THE PADS FROM THE LOAD

⚠ WARNING: *Load must be fully supported before releasing vacuum pads.*

The lifter is designed to prevent an accidental load release, which could result from unintentionally interrupting the apply mode: When the load is at rest and fully supported, press and hold the enable button and the release button on the lifter, to force air into the vacuum pads, quickly breaking the vacuum seal. Alternatively, if the lifter is equipped with a Remote Control System, press and hold the enable button and a release button on the radio transmitter. Continue to hold both buttons until the vacuum pads disengage completely from the load.

If the lifter is equipped with a Remote Control System, a strobe light flashes as long as the operator is pressing the enable or release buttons. This serves to show the operator when signals are being transmitted successfully from a remote location and also to warn other personnel that the operator is suspending the apply function.

⚠ WARNING: *If vacuum pads do not disengage completely, do not attempt to move the lifter or load.*

The operator must never attempt to move the lifter or load until the vacuum pads are completely disengaged, as this could cause an unexpected load release and potential injury to the operator or others. If the vacuum pads do not disengage completely on the first attempt, repeat the release process. If the load cannot be successfully released for any reason, reapply the vacuum pads to the load as previously directed (see TO APPLY THE PADS TO A LOAD preceding) prior to moving the lifter or load.

After the load is successfully released, the lifter will automatically activate a stand-by mode to conserve the battery energy until the lifter is ready to lift another load. Once the stand-by mode is activated, only the blue power light remains illuminated.

Prior to lifting another load, perform the Every-Lift Inspection as directed in MAINTENANCE: INSPECTION SCHEDULE.

AFTER USING THE LIFTER

Make sure the power switch on the lifter is in the OFF () position. The power light shuts off when the operator powers down the lifter.

CAUTION: Do not set the lifter against any surfaces which could soil or damage the vacuum pads.

Use the hoisting equipment to gently lower the lifter onto a stable support; then detach the hoisting equipment hook from the lift spool.

If the lifter is transported to another location, use the original shipping container and secure the lifter so as to protect the vacuum pads and all other components from damage while in transit.

Storing the Lifter

Use the covers supplied to keep the vacuum pads clean.

.....
!!-CE-!! In accordance with CE Standard EN 13155, the lifter is designed to rest on relatively horizontal surfaces without tipping over. To store the lifter in this way, set the lifter with the pads facing downward on a clean, smooth, flat surface. Then lower the lift bar to a horizontal orientation and place a support under the lift spool.
.....

Charge the battery completely when placing it in storage and at six-month intervals thereafter (see MAINTENANCE: BATTERY RECHARGE). After charging the battery, disconnect the electrical connectors uniting the battery to the battery charger and to the vacuum generating system, in order to minimize power drainage. Preferred temperatures for storing the battery are 32° to 70° Fahrenheit [0° to 21° Celsius]. Higher temperatures require the battery to be charged more frequently. Storage at temperatures above 100° Fahrenheit [38° Celsius] should be avoided.

MAINTENANCE

 **WARNING:** Always make sure battery is disconnected before servicing lifter.

Note: One or more wiring diagrams are provided in the final section of this *INSTRUCTIONS* manual for reference when servicing the lifter or trouble-shooting a deficiency.

INSPECTION SCHEDULE

Perform inspections routinely, according to the following frequency schedule:

Every-Lift Inspection

- Examine the vacuum pads and load surface for contamination or debris (see VACUUM PAD MAINTENANCE to follow).
- Examine the vacuum pads, controls and indicators for visual damage (see VACUUM PAD MAINTENANCE to follow).
- Test the battery for adequate charge (see BATTERY TEST to follow).

If a battery's charge appears to be inadequate, charge and retest the battery (see BATTERY RECHARGE to follow). If any other deficiency is detected during the inspection, correct it before using the lifter and perform the Frequent Inspection to follow.

Frequent Inspection

(following every 20-40 hours' use; or whenever lifter is out of service for 1 month or more)

- Examine the lifter's structure for visual damage.
- Examine the vacuum system (including vacuum pads, fittings and hoses) for visual damage.
- Examine the air filters for conditions requiring service (see AIR FILTER MAINTENANCE to follow).
- Perform the VACUUM TEST to follow.
- Check for unusual vibrations or noises while operating the lifter.
- If the lifter is equipped with a Remote Control System, perform the REMOTE CONTROL SYSTEM TEST to follow.

If any deficiency is detected during the inspection, correct it before using the lifter and perform the Periodic Inspection to follow.

Periodic Inspection

(following every 250-500 hours' use; or whenever lifter is out of service for 1 year or more)

- Examine the entire lifter for external evidence of looseness, excessive wear, deformation, cracks, excessive corrosion, dents to structural or functional components, cuts, or any deficiency which might constitute a hazard.
- Inspect all parts of the electrical system for damage, wear or contamination that could constitute a hazard, in compliance with all local codes and regulatory standards that are relevant for the geographical region.

CAUTION: *Be sure to use appropriate cleaning methods for each type of electrical component, as specified by codes and standards. Improper cleaning can damage components.*

- Keep a written record of all Periodic Inspections.

If any deficiency is detected during the inspection, correct it before using the lifter. If necessary, return the lifter to Wood's Powr-Grip or an authorized dealer for repair (see LIMITED WARRANTY).

Infrequent Use

If a lifter is used less than 1 day in a 2-week period, perform the Periodic Inspection *each time before using the lifter.*

TESTING SCHEDULE

Perform these tests when placing the lifter in service *initially* and *each time following a repair or modification.* Correct any deficiency and retest before using the lifter.

Operational Tests

- Perform the VACUUM TEST to follow.
- Test all features and functions of the lifter (see OPERATING FEATURES, OPERATION and MAINTENANCE).

Load Test

Prove that the lifter can lift 100% of its Maximum Load Capacity (see SPECIFICATIONS), using an actual load or an equivalent simulation.¹³ Employ the following method to test with an actual load:

- 1) Place a test load with appropriate LOAD CHARACTERISTICS (see INTENDED USE) on a stable support. Make sure the load is oriented in the upright position.¹⁴
- 2) Apply the vacuum pads to the load as previously directed.
- 3) After the vacuum pump stops running, place the lifter's power switch in the "OFF" position.
- 4) Raise the load a minimal distance, to assure that it is supported by the lifter.
- 5) Hold the load for 5 minutes. The load must not slip or fall during this time period. If it does, conduct a VACUUM TEST and inspect each vacuum pad as indicated under VACUUM PAD MAINTENANCE: Inspection (see sections to follow). Correct any deficiency that is found and retest the lifter.

Note: See MAINTENANCE topics to follow for additional directions about inspecting and testing specific lifter components. Since the low vacuum warning buzzer is controlled by a vacuum switch, consult the VACUUM SWITCH ADJUSTMENT discussion for inspection, testing and adjustment procedures.

¹³ ASME Standard B30.20 requires the lifter to be tested to 125% of its Load Capacity.

¹⁴ Flat Lifters are exempt from this requirement.

MAINTENANCE SCHEDULE

Unless specified elsewhere in this *INSTRUCTIONS* manual, the lifter does not require maintenance on a routine basis. Instead, maintenance must be performed whenever a deficiency is indicated by routine inspections or tests. Any maintenance warranted must be performed before resuming normal operation of the lifter.

BATTERY TEST

The lifter is equipped with a battery gauge to help the operator evaluate whether the battery has adequate energy for lifting. Factors such as the condition of the battery, the time required to execute a lift, and the porosity of the load combine to determine how much battery energy is needed. ***It is the operator's responsibility to evaluate these conditions and to make sure the battery has sufficient energy to complete a lift safely.*** Check the battery energy before every lift and also at the end of each day's use, to decide whether a charge is needed (see BATTERY RECHARGE to follow).¹⁵ Never use the lifter when battery energy registers lower than 50% (that is, when only red lights are illuminated), regardless of the estimated energy requirement.

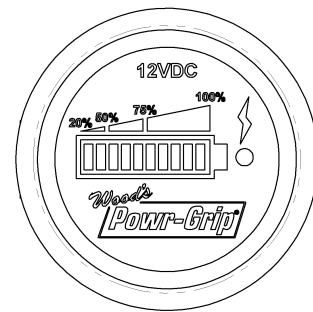

⚠ WARNING: Never use lifter if battery energy is lower than 50% of capacity.

While the lifter's power switch is in the "ON" position, the battery gauge automatically monitors battery energy (provided that the lifter is not in stand-by mode). However, the battery gauge shuts off temporarily while the vacuum pump is running, to prevent an inaccurate reading. When the pumping cycle is completed, the battery gauge requires a few moments to stabilize before it displays an accurate energy reading again.

While the lifter's power switch is in the "OFF" position (or the lifter is in stand-by mode), the battery energy can be checked manually using the battery test button. If the lifter has not been used since the battery was charged, the battery gauge may falsely indicate an energy level that is higher than actual, due to a "surface charge" on the battery. After the pump runs for approximately one minute, the surface charge dissipates, allowing the operator to take an accurate energy reading.

BATTERY RECHARGE

Only use a battery charger supplied by or approved by Wood's Powr-Grip; other chargers may reduce battery life. Charge the battery as soon as possible after any extended use of the lifter, or whenever the battery gauge indicates diminished energy (see BATTERY TEST preceding). Temperatures above 70° Fahrenheit [21° Celsius] require the battery to be charged more frequently. ***CAUTION: Charge the battery only while the lifter's power switch is in the "OFF" position.*** Operating the lifter when the charger is connected to an AC power source could result in permanent damage to the charger.

¹⁵ The battery charger must be disconnected from its AC power source in order to test the battery energy; otherwise, the energy reading on the battery gauge would not be accurate.

Identify the input voltage marked on the battery charger, and plug it in to an appropriate power source.¹⁶ The power source must be equipped with a ground fault circuit interrupter, in order to reduce the risk of electrical shocks.

 **WARNING: Power source must be equipped with ground fault circuit interrupter.**

Usually a battery takes no more than 16 hours to charge completely, after which the charger shuts off automatically. The blue light on the battery gauge also turns on, to indicate that the battery is fully charged. Following long-term use, a battery gradually loses capacity. Replace it whenever the operating time between recharging is no longer satisfactory.

BATTERY CHARGER TEST

Perform this test only when the battery is *not* fully charged (see BATTERY TEST preceding). While the lifter's power switch is in the "OFF" position and the battery charger is *disconnected* from any AC power source, use the battery test button to take an energy reading on the battery gauge. Then plug the charger in to an appropriate AC power source and allow a few moments for the battery gauge to show an accurate energy reading. If the charger is functioning correctly, the energy reading should be higher when the charger is plugged in.

VACUUM PAD MAINTENANCE

Friction Coefficient

The friction coefficient represents the lifter's ability to resist load slippage when the load is oriented in any position except horizontal. If the contact surfaces of either the load or the vacuum pads are not clean, dry and in good condition, slippage is more likely to occur.

The Load Capacity of most Powr-Grip lifters is based on a friction coefficient of 1 (only Flat Lifters are exempt from this requirement). However, a vacuum pad's ability to maintain this friction coefficient is reduced by factors such as contamination, wear, age and exposure to sunlight, as well as the condition of the load's contact surface (see INTENDED USE: LOAD CHARACTERISTICS). Pads that have surface contamination must be thoroughly cleaned (see Cleaning discussion to follow). Over time, the rubber in a pad may experience hardening or leaching of chemicals, resulting in stiffness or surface glaze. Pads that exhibit wear, stiffness or glaze must be replaced.

In addition, all pads should be replaced on a regular basis, preferably after no more than 2 years, to ensure that the friction coefficient is not compromised. If necessary, contact your dealer or Wood's Powr-Grip for more information.

¹⁶ Any external power supply must conform to all applicable local codes.

Inspection

Inspect each vacuum pad for the following deficiencies routinely, as directed in the preceding INSPECTION and TESTING SCHEDULES. Correct any deficiency before using the lifter.

- Contaminates on the pad face or sealing edges: Soil build-up can prevent pads from sealing adequately or reduce the friction coefficient (see discussion preceding). Follow the directions to clean pads as necessary (see discussion to follow).
- Filter screen missing from pad face: This screen helps prevent debris from plugging the vacuum hose and the air filter. Replace any missing screen immediately (see REPLACEMENT PARTS LIST).
- Nicks, cuts or abrasions in sealing edges: Pad damage can reduce the lifting capacity of the lifter. Replace any damaged pad immediately (see REPLACEMENT PARTS LIST).

 **WARNING: Replace vacuum pad if sealing edge has any nicks, cuts or abrasions.**

- Wear, stiffness or glaze: See Friction Coefficient preceding. Replace any pad that exhibits wear, stiffness or glaze (see REPLACEMENT PARTS LIST).

Cleaning

Regularly clean the face of each vacuum pad to remove oil, dust and any other contaminants. Acceptable cleaning agents include soapy water and other mild cleansers. Do *not* use solvents, petroleum-based products (including kerosene, gasoline and diesel fuel) or any harsh chemicals for cleaning. Do *not* use unauthorized rubber cleaners or conditioners, such as those intended for cleaning tires or vinyl surfaces, because those products can leave a hazardous film on vacuum pads which significantly reduces their lifting capacity (see Friction Coefficient preceding). The use of any unauthorized cleaning agent is prohibited because it could damage the pad and/or create a hazard to the operator or others.

 **WARNING: Never use solvents, gasoline or other harsh chemicals to clean vacuum pad.**

 **WARNING: Never use unauthorized rubber cleaners or conditioners to clean vacuum pad.**

To prevent liquid from contaminating the vacuum system during cleaning, cover the suction hole in the recess for the filter screen or make sure the pad faces downward. Use a clean sponge or lint-free cloth to apply an authorized cleanser and wipe the pad face clean. A toothbrush (or similar brush with bristles *that do not harm rubber*) may be used to remove contaminants clinging to sealing edges.¹⁷ Wipe all residue from the pad face, and allow the pad to dry completely before using the lifter.

¹⁷ If these cleaning methods are not successful, contact Wood's Powr-Grip or an authorized dealer for assistance.

VACUUM TEST

Test the vacuum system for leakage routinely, as directed in the preceding INSPECTION and TESTING SCHEDULES.

- 1) Clean the face of each vacuum pad as previously directed (see VACUUM PAD MAINTENANCE: Cleaning).
- 2) Apply the lifter to a clean, smooth, nonporous surface. The surface should be flat or possess no more curvature than the lifter is designed for (if any).¹⁸ When the pumping cycle is completed, the vacuum level should register above 16" Hg [-54 kPa] on each of the vacuum gauges (if not, see VACUUM SWITCH ADJUSTMENT to follow).
- 3) After the vacuum pump stops running, leave the pads attached to the surface and place the lifter's power switch in the "OFF" position, to interrupt the energy flow from the battery.
- 4) Monitor the vacuum gauges: *The vacuum level should not decrease by more than 4" Hg [-14 kPa] in 10 minutes.*¹⁹

 **WARNING:** *If lifter fails vacuum test, discontinue use immediately.*

Correct any deficiency in the vacuum system before using the lifter. Contact Wood's Powr-Grip or an authorized dealer for assistance.

REMOTE CONTROL SYSTEM TEST

If the lifter is equipped with a Remote Control System, perform this test in the environment where the lifter is normally employed. Use the radio transmitter to activate each of the remote functions.²⁰ Vary the location and distance of the transmitter in relation to the lifter, to ensure that transmissions are effective in a variety of circumstances. This may require assistance from someone near the lifter, to verify that functions are being performed as intended.

If the Remote Control System does not function correctly, review the following potential causes of malfunction and correct them as directed:

- The battery for the radio transmitter may be worn out. Replace any expended battery (see REPLACEMENT PARTS LIST).
- Metal or other electrically conductive surfaces may be causing interference between the radio transmitter and radio receiver. Although the transmission signals often can bounce around interfering surfaces, the signals do not travel through conductive walls. Reposition the transmitter as necessary to transmit signals effectively.

If the preceding directions do not resolve a performance problem, repeat the test under different conditions, to determine whether there is transmission interference in the work environment or the Remote Control System is not functioning as intended. Correct any deficiency before resuming normal use of the Remote Control System. If necessary, contact Wood's Powr-Grip or an authorized dealer for assistance.

¹⁸ Any test material used must be fully and independently supported, and capable of bearing the lifter's weight. Do not use the lifter to lift the test material during the vacuum test.

¹⁹ Vacuum pads for cladding and textured materials are designed with a higher leak-off rate than standard rubber vacuum pads from Wood's Powr-Grip. When you are performing a vacuum test for lifters with such pads, use the following standard: The vacuum level should not decrease by more than 4" Hg [-14 kPa] in 5 minutes.

²⁰ Use a test material with appropriate surface characteristics (see INTENDED USE: LOAD CHARACTERISTICS) to test the apply and release functions.

AIR FILTER MAINTENANCE

(for in-line filters)

Filter Function and Conditions Requiring Service

This air filter prevents solid particles from contaminating components in the vacuum system.

CAUTION: *Examine air filter regularly and empty when necessary.*

Open each filter regularly to determine whether liquid or other contaminants are trapped inside. Remove any liquid or contaminants found. Clean or replace the filter element if it has an overall dirty appearance, or if there is a noticeable increase in the time required to attain full vacuum (see REPLACEMENT PARTS LIST).

Filter Service Procedures

- 1) Hold the filter case (1) and turn the removable end (2) counter-clockwise approximately 45° until it stops moving.
- 2) Pull the end outward from the case and remove the filter element (3). Use an air hose or other suitable means to remove any liquid or other contaminants found inside the case. Also make sure the seal (4) is not damaged.
- 3) Determine whether the filter element needs to be replaced (see Conditions Requiring Service above).
- 4) Depending on the outcome of step 3, install a new element or reinstall the old element, as shown in the illustration.
- 5) Align the 2 projections on the removable end with the grooves in the case, and insert the end into the case. Push in and turn the end clockwise approximately 45° until it stops moving. Make sure that the projections are completely visible through the windows (5) in the case.
- 6) Test the vacuum system, to make sure the air filter does not leak (see VACUUM TEST preceding).

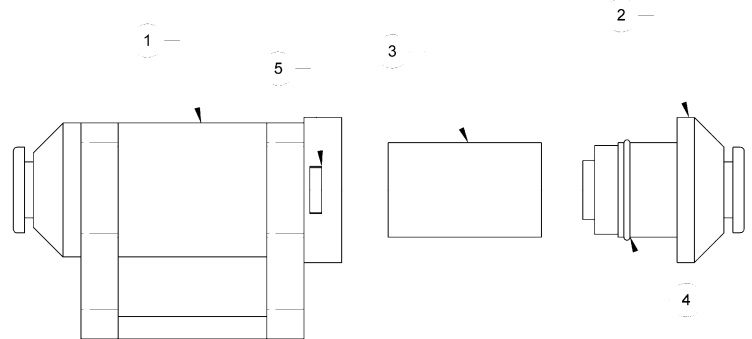

VACUUM PUMP MAINTENANCE – DYNAFLO DV1032102

⚠ WARNING: Before proceeding with any maintenance, disconnect power source.

If the vacuum pump takes too long to attain full vacuum, it may require maintenance. Replace the diaphragm, gasket/flap valves or (when preferable) the entire head assembly²¹ (see REPLACEMENT PARTS LIST), as necessary to obtain acceptable pump performance.

CAUTION: Do not over-tighten the head screws, because this may damage the threads in the pump body.

Replacing the Diaphragm

1) Remove the four head screws (1) and lock washers (2), and remove the head assembly (3–7).

2) Remove the diaphragm retaining screw (8), diaphragm (9) and rubber O-ring (10).

Note: Be sure to save the flat washer located between the O-ring and the connecting rod (11). Also take note of the diaphragm orientation for reassembly.

3) Replace the diaphragm, rubber O-ring and diaphragm retaining screw. Reinstall the flat washer in its original position.

4) Reverse the steps above for reassembly, as shown in the illustration.

Replacing the Gasket/Flap Valves

1) Remove the four head screws (1) and lock washers (2), and remove the head assembly (3–7).

2) Invert the head and remove the two valve plate screws (7). Remove the valve plate (6) to access the gasket/flap valves.

3) Replace the gasket/flap valves (5) and reverse the steps above for reassembly, as shown in the illustration. Use the alignment pin (15) to ensure proper fit between the head and valve plate.

Replacing the Head Assembly

1) Remove the four head screws (1), lock washers (2) and head assembly (3–7).

2) Replace the head assembly, and reverse the steps above for reassembly, as shown in the illustration.

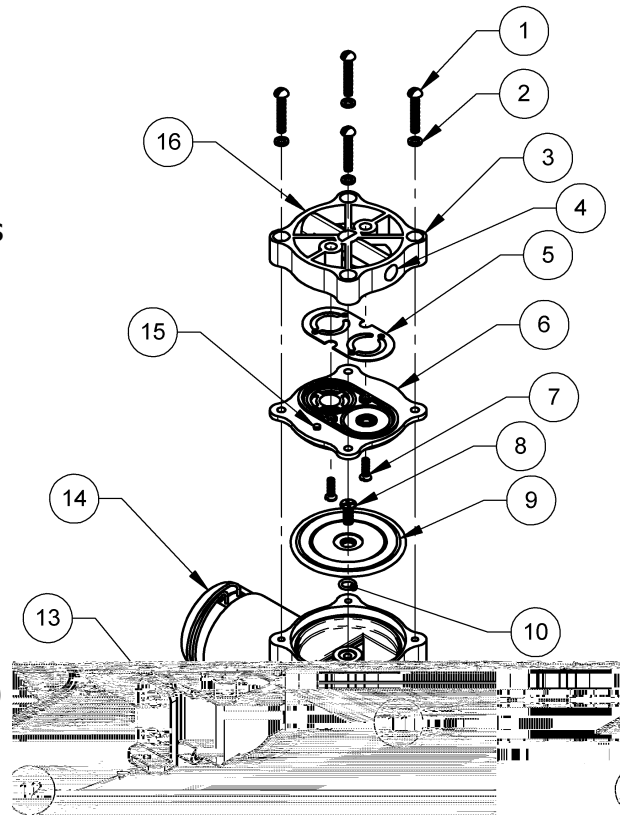

1 HEAD SCREW	5 GASKET/FLAP VALVES	9 DIAPHRAGM	13 WIRES
2 LOCK WASHER	6 VALVE PLATE	10 RUBBER O-RING	14 MOTOR
3 HEAD	7 VALVE PLATE SCREW	11 CONNECTING ROD	15 ALIGNMENT PIN
4 INTAKE PORT	8 DIAPHRAGM RETAINING SCREW	12 MOUNTING FOOT	16 EXHAUST PORT

²¹ **CAUTION:** Depending on the product, the head assembly (3–7) may be rotated to an orientation different from the one shown. When removing the head assembly, always take note of its orientation and install it the same way during reassembly. Make sure that the intake and exhaust ports remain in their original positions.

VACUUM PUMP MAINTENANCE – THOMAS 107CDC20

⚠ WARNING: Before proceeding with any maintenance, disconnect power source.

If the vacuum pump (14) takes too long to attain full vacuum, it may require maintenance. Replace the diaphragm, valve flappers or head gasket as necessary to obtain acceptable pump performance (see REPLACEMENT PARTS LIST).

Replacing the Diaphragm

- 1) Remove the four head screws (1) and remove the head (2).
- 2) Remove the four diaphragm hold-down screws (10) and the diaphragm hold-down plate (12).
- 3) Replace the diaphragm (13) and reverse the steps above for reassembly.

Replacing the Intake Valve Flapper

- 1) Remove the four head screws (1) and remove the head (2).
- 2) Remove the intake valve flapper screw (8) and the intake valve keeper (7).
- 3) Replace the intake valve flapper (11) and reverse the steps above for reassembly.

Replacing the Exhaust Valve Flapper and Head Gasket

- 1) Remove the four head screws (1) and remove the head (2).
- 2) Invert the head and remove the four valve plate screws (9).
- 3) Lift out the valve plate (6) to access the exhaust valve flapper and head gasket.²²
- 4) Remove the exhaust valve flapper screw (3) and the exhaust valve keeper (4), and replace the exhaust valve flapper (5).
- 5) Replace the head gasket (15) and reverse the steps above for reassembly.

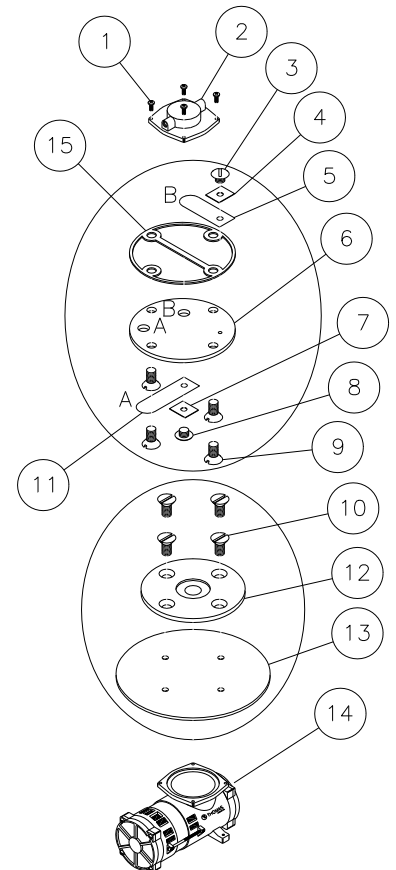

1 HEAD SCREWS	6 VALVE PLATE	11 INTAKE VALVE FLAPPER
2 HEAD	7 INTAKE VALVE KEEPER	12 DIAPHRAGM HOLD-DOWN PLATE
3 EXHAUST VALVE FLAPPER SCREW	8 INTAKE VALVE FLAPPER SCREW	13 DIAPHRAGM
4 EXHAUST VALVE KEEPER	9 VALVE PLATE SCREWS	14 VACUUM PUMP
5 EXHAUST VALVE FLAPPER	10 DIAPHRAGM HOLD-DOWN SCREWS	15 HEAD GASKET

²² **CAUTION:** Depending on the product, the vacuum system may require the valve plate (6) to be rotated to an orientation different from the one shown. When removing the valve plate, always take note of its orientation in the pump head (2), and install the valve plate the same way during reassembly. In all cases, the valve plate must be oriented so that its intake hole is matched with the head port that connects to the check valve.

VACUUM SWITCH ADJUSTMENT

Vacuum Switch Function

This vacuum lifter is equipped with a vacuum switch, which controls the low vacuum warning buzzer, vacuum lift light and vacuum pump (see OPERATING FEATURES for location of vacuum switch): The power switch activates the warning buzzer and the pump, which evacuates the vacuum pads. After the lifter attains a vacuum level sufficient for lifting the maximum load weight (hereafter, "minimum lifting level"), the vacuum switch automatically turns off the pump and the warning buzzer²³ while it turns on the lift light. In order to maintain sufficient vacuum, the vacuum switch automatically turns on the pump and warning buzzer again (while it turns off the lift light) before vacuum decreases to a level that is lower than the minimum lifting level.

Conditions Requiring Readjustment

At the factory, the vacuum switch is set to maintain the minimum vacuum level specified for the Load Capacity (see SPECIFICATIONS). However, shipping vibrations or shocks, normal wear, or other conditions may adversely affect this adjustment. Periodically verify the switch adjustment by comparing how the vacuum pump, low vacuum warning buzzer and vacuum lift light function in relation to the vacuum level registered on the vacuum gauges, as follows:

- If the pump and the warning buzzer do not *turn off* or the lift light does not *turn on after* vacuum increases to a level much *higher* than the minimum lifting level, the vacuum switch may be adjusted to maintain a lower vacuum level. Otherwise, the pump would continue to run unnecessarily after the lifter has attained sufficient vacuum to lift the maximum load weight.
- If the pump and the warning buzzer do not *turn on* or the lift light does not *turn off before* vacuum decreases to a level *lower* than the minimum lifting level, the vacuum switch ***must be adjusted to maintain a higher vacuum level.***²⁴ Otherwise, the lifter would not maintain sufficient vacuum to lift the maximum load weight.

²³ When using the lifter at high elevations, reduced atmospheric pressure may prevent the vacuum generating system from attaining the vacuum level set at the factory. In this case, the pump would continue to run and the warning buzzer would sound an alarm continuously. If the ability to lift the maximum load weight is not required, the operator can adjust the vacuum switch to maintain a lower vacuum level, allowing the pump to cycle normally. However, be advised that ***lifting capacity decreases proportionally with decreasing vacuum***, based on the vacuum level specified for the Load Capacity (see SPECIFICATIONS). For example, if a lifter's Load Capacity is rated at 16" Hg [-54 kPa], lifting capacity decreases by 6.25% for each inch of Hg subtracted from (or for each 3.4 kPa added to) the vacuum level. ***Always maintain a minimum vacuum level of 10" Hg [-34 kPa]***, regardless of the vacuum level specified for the original Load Capacity. In addition, lifter markings should be adjusted to reflect the revised Load Capacity and the vacuum gauges should be marked to indicate the revised minimum lifting level.

²⁴ In order to observe lifter functions while vacuum is decreasing, it may be necessary to create a controlled leak in the vacuum system (eg, by breaking the seal between one or more vacuum pads and the test surface). Since the lifter is equipped with a Dual Vacuum System, a leak should be introduced in each of the 2 vacuum circuits, which can be identified by differently colored vacuum hoses.

Adjustment Procedure

⚠ WARNING: *Lifting capacity decreases whenever vacuum switch is adjusted to maintain lower vacuum level.*

- 1) Locate the access hole in the enclosure that contains the vacuum switch (see OPERATING FEATURES), and remove the plug from the hole. Using a flat-blade screwdriver, turn the adjustment screw on the vacuum switch about 1/6th turn at a time.

To maintain a *lower* vacuum level, turn the screw *clockwise*.

To maintain a *higher* vacuum level, turn the screw *counter-clockwise*.

- 2) Recheck the vacuum switch setting following each 1/6th turn of the adjustment screw. In order to test the adjustment accurately, release the vacuum pads completely before reapplying them to a test surface.

When a vacuum switch is adjusted correctly, the vacuum pump turns off only *after* vacuum increases to a level higher than the minimum lifting level; and the pump turns on again *before* vacuum decreases to a level lower than the minimum lifting level.

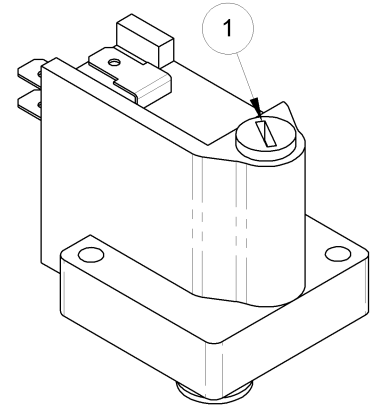

VACUUM SWITCH

1) ADJUSTMENT SCREW

REPLACEMENT PARTS LIST

Stock No.	Description	Qty.
93220	Vacuum Pump - Diaphragm Type - 1-SCFM [28 liters/minute] - 12 V DC (Dynaflor)	1
66197BM	Dynaflor Pump Gasket & Flap Valves	1
66197AM	Dynaflor Pump Diaphragm Kit	1
66197	Dynaflor Pump Head Assembly	1
66195	Thomas Pump Repair Kit (including diaphragm, head gasket and valve flappers)	1
66130	Vacuum Pump - Diaphragm Type - 1-SCFM [28 liters/minute] - 12 V DC (Thomas)	1
65442CA	Vacuum Hose - 0.160" [4.1 mm] ID - Red (approx. 10" [25 cm] in length)	1
65440	Vacuum Hose - 1/4" [6.3 mm] ID - Red (approx. 100" [254 cm] in length)	1
65439	Vacuum Hose - 3/32" [2.4 mm] ID - Blue (approx. 5" [13 cm] in length)	1
65438	Vacuum Hose - 1/8" [3.1 mm] ID - White (approx. 24" [61 cm] in length)	1
65437	Vacuum Hose - 1/4" [6.3 mm] ID - Green (approx. 100" [254 cm] in length)	1
65429	Vacuum Hose - 0.160" [4.1 mm] ID - Blue (approx. 90" [229 cm] in length)	1
65301	Handle Grip Foam (approx. 17" [43 cm] in length)	1
65211	Check Valve - 1/8 NPT	2
65014	Pad Spring - Wave Type (for HV11 pad)	6
65010	Pad Spring - Coil Type (for G3370 & G0750 pads)	6
64834	LED Indicator - 12 V DC - Green (aka, vacuum lift light)	1
64832	LED Indicator - 12 V DC - Blue - Small (aka, power light)	1
64752	Audio Alarm - 5-15 V DC - Panel Mount	1
64707AS	Battery Charger - 240 V AC - Australian Type	1
64706AZ	Battery Charger - 240 V AC	1
64702AM	Battery Charger - 100 / 120 V AC	1
64682	Battery - 1.5 V DC - AA Alkaline (for radio transmitter)	2
64664	Battery - 12 V DC - 7 Amp-Hours	1
64590	Battery Gauge	1
64460	Circuit Breaker - 15 A	1
64453CP	Circuit Board - Populated	1
64271	Strobe Light - 12 V DC - Amber (option)	1
64238BA	Vacuum Switch - 10-32 Thread	1
64233	Power Switch	1
64213	Push-Button Switch - Chrome (for apply, enable, and release buttons)	3
64199	Push-Button Switch - Red (for battery test button)	1
57388	Remote Control System Retrofit Kit (option)	1
54392	Battery Connector - Twin Lead	1
53132	Hose Fitting - Tee - 5/32" [4.0 mm] ID	1
53128	Pad Fitting - Tee - 5/32" [4.0 mm] ID	2
53122	Pad Fitting - Elbow - 5/32" [4.0 mm] ID	4
49646T	Vacuum Pad - Model G3370 / 11" [28 cm] Diameter - Lipped	6
49643T	Vacuum Pad - Model G3370 / 11" [28 cm] Diameter - Lipped - Low-Marking (option)	6
49614T	Vacuum Pad - Model HV11F / 10" [25 cm] Diameter - Lipped w/Foam Ring (option)	6
49605T	Vacuum Pad - Model HV11 / 10" [25 cm] Diameter - Lipped (option)	6
49586TA	Vacuum Pad - Model G0750 / 10" [25 cm] Diameter - Concave (option)	6
49150	End Plug - 2 1/2" x 2 1/2" x 1/4" [63.5 mm x 63.5 mm x 6.4 mm] Tubing Size	1
29353	Pad Cover	6
16131	Element for Air Filter	2
16057	Quick Connector - 1/8 FNPS - Male End	2
16056	Quick Connector - 1/8 FNPS - Female End	2
15920	Vacuum Gauge - 1/8 NPT - CBM Type - w/Panel Mount Bracket	2
15792AM	Rotation or Tilt Release Lever Knob	2
15632	Pad Filter Screen - Small (for G0750 pad)	6
15630	Pad Filter Screen - Large (for G3370 & HV11 pads)	6
10898	Shoulder Bolt - Socket Head - 5/16" x 3/8" x 1/4-20 Thread (for mounting pads)	36

**SERVICE ONLY WITH IDENTICAL REPLACEMENT PARTS
SUPPLIED BY OR APPROVED BY WOOD'S POWR-GRIP CO., INC.**

LIMITED WARRANTY

Powr-Grip products are carefully constructed, thoroughly inspected at various stages of production, and individually tested. They are warranted to be free from defects in workmanship and materials for a period of one year from the date of purchase.

If a problem develops during the warranty period, follow the instructions hereafter to obtain warranty service. If inspection shows that the problem is due to defective workmanship or materials, Powr-Grip will repair the product without charge.

WARRANTY DOES NOT APPLY WHEN:

Modifications have been made to the product after leaving the factory.

Rubber portions have been cut or scratched during use.

Repairs are required due to abnormal wear and tear.

The product has been damaged, misused, or neglected.

If a problem is not covered under warranty, Powr-Grip will notify the customer of costs prior to repair. If the customer agrees to pay all repair costs and to receive the repaired product on a C.O.D. basis, Powr-Grip then will proceed with repairs.

TO OBTAIN REPAIRS OR WARRANTY SERVICE

For purchases in *North America*:

Contact the Technical Service Department at Wood's Powr-Grip Co.. When factory service is required, ship the complete product--prepaid--along with your name, address and phone number to the street address hereafter.

For purchases in *all other localities*:

Contact your dealer or the Technical Service Department at Wood's Powr-Grip Co. for assistance.

Wood's Powr-Grip Co., Inc.
908 West Main St. / P.O. Box 368
Laurel, MT USA 59044

phone 800-548-7341

phone 406-628-8231

fax 406-628-8354

TYPE: **STANDARD**
 DIRECTORY: H:\Working\STD\713-RC\ECN 2880\713-W01 [W01]
 FILE [SHEET]:
 THIS DRAWING IS THE PROPERTY OF **WOOD'S POWR-GRIP CO., INC.**
 IT IS LOANED WITH THE UNDERSTANDING THAT NEITHER IT NOR ANY
 INFORMATION CONTAINED THEREIN WILL BE COPIED, PUBLISHED OR
 TRANSMITTED TO OTHERS WITHOUT EXPRESS WRITTEN PERMISSION.
 LAUREL, MONTANA, U.S.A.

RADIO REMOTE CONTROL
 N/A
CONTROL ENCLOSURE WIRING
 D713-W01 [W01]

SIZE: SCALE: **A NONE** REV.: **0** ECN NUMBER: **2880, REL. FOR PROD.** DATE: **06/06/2012** BY: **LER**

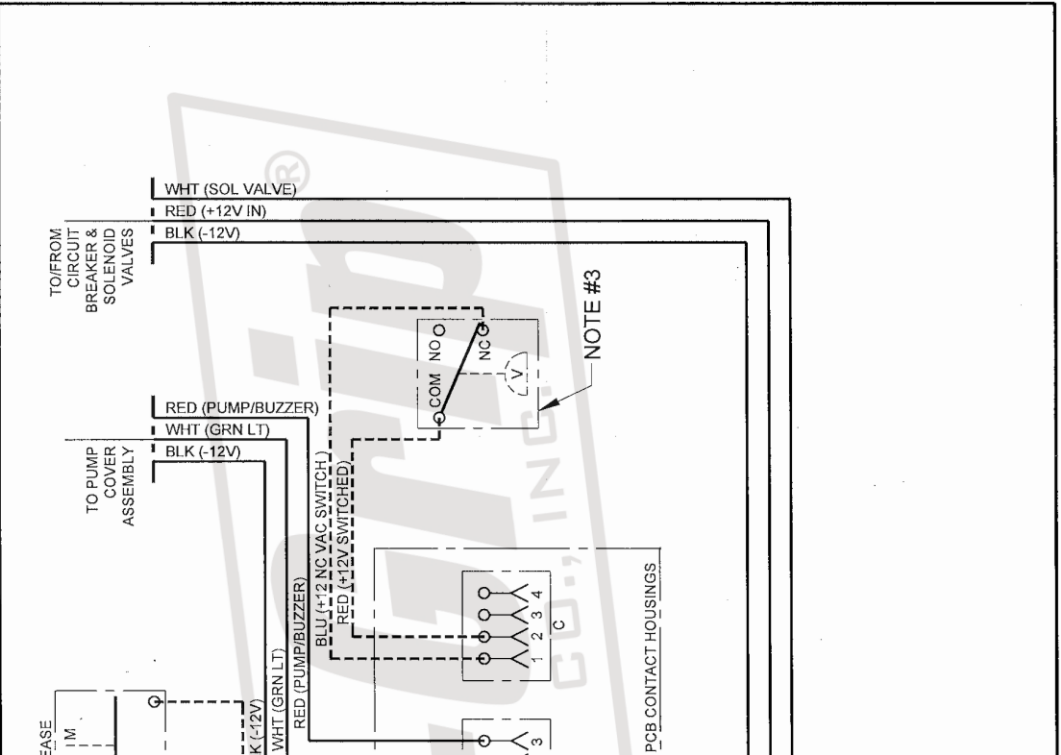

18/RUB

DIRECTORY: H:\Working\STD\775-MRTALP\ECN 2976\ 775B-W01 [B-W01]
TANDARD FILE (SHEET):

THIS DRAWING IS THE PROPERTY OF **WOOD'S POWR-GRIP CO., INC.** LAUREL, MONTANA, U.S.A.
NO INFORMATION CONTAINED HEREIN WILL BE COPIED, PUBLISHED OR TRANSMITTED TO OTHERS WITHOUT EXPRESS WRITTEN PERMISSION.

1100# LOW-PROFILE MANUAL ROTATOR/QUADRA-TILTER
CHANNEL PAD FRAME
WIRING SCHEMATIC
D775B-W01 [B-W01]

SCALE: NONE REV.: 0 ECN NUMBER: 2976 DATE: 09/13/2012 BY: RAS EST. WEIGHT: N/A

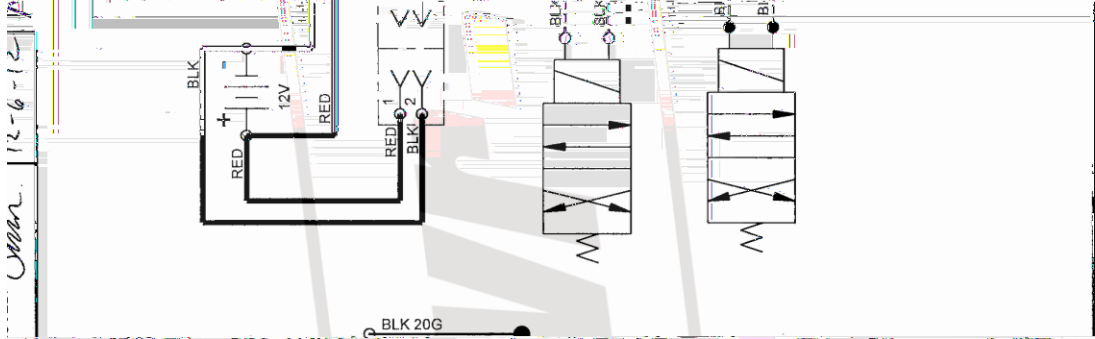

RE LEGEND: CONTROLLED BY WIRING SYMBOLS DRAWING EXCEPT AS NOTED AND BELOW.
LINE STYLES AND WIDTHS FOR WIRE UNLESS NOTED OTHERWISE.

---	18 AWG
---	22 AWG
---	14 AWG
---	18 AWG

DATE: 09/13/2012
DRAWN: SCHNEIDER
CHECKED: CR
REVISED: 12-05-12

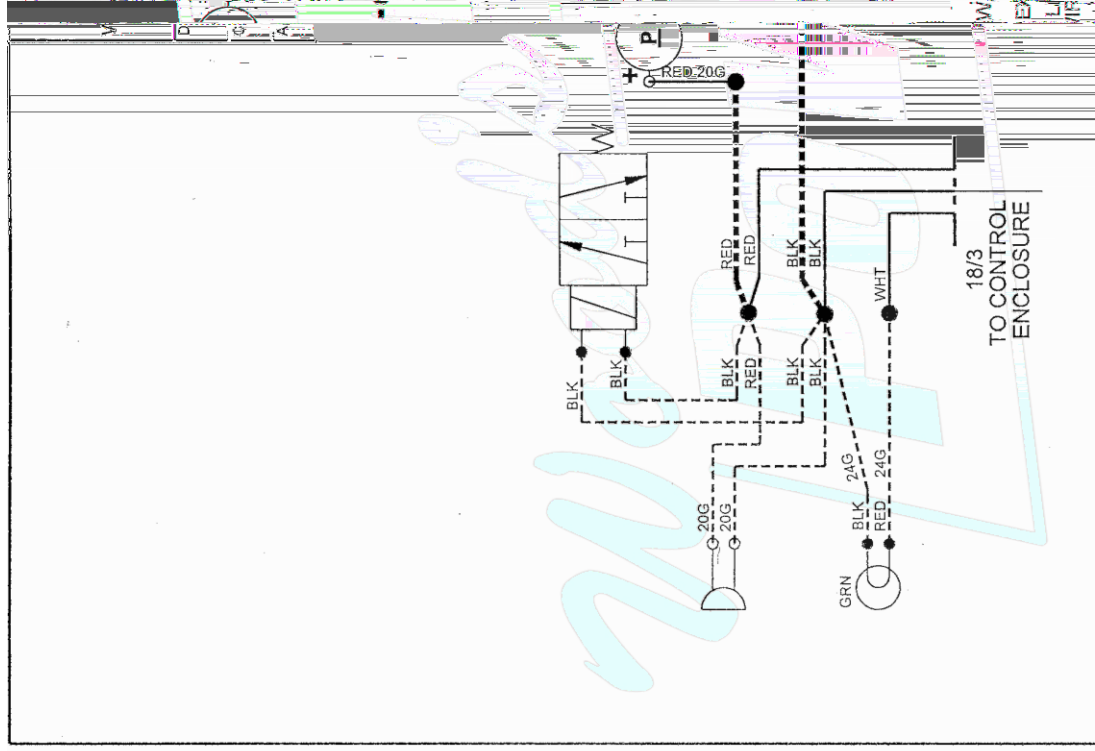

1: BK06
H:\Working\STD\775-MRTALPCH6 2976

ROLLED BY: 01 EXCEPTED BELOW.	TYPE: STANDARD	DIRECTORY: FILE (SHEET):	775B-W02 [B-W02]
FRACTIONAL X/XX ± N/A "S Ø XXX ± N/A > Ø XXX ± N/A DO NOT SCALE.	THIS DRAWING IS THE PROPERTY OF WOOD'S POWR-GRIP CO., INC. IT IS LOANED WITH THE UNDERSTANDING THAT NEITHER IT NOR ANY INFORMATION CONTAINED THEREIN WILL BE COPIED, PUBLISHED OR TRANSMITTED TO OTHERS WITHOUT EXPRESS WRITTEN PERMISSION. LAUREL, MONTANA U.S.A.		
DATE: 09/13/2012	1100# LOW-PROFILE MANUAL ROTATOR/QUADRA-FILTER CHANNEL PAD FRAME PNEUMATIC SCHEMATIC D775B-W02 [B-W02]		
12-05-12	SIZE: SCALE: A NONE	REV: 0	ECN NUMBER: 2976
12-6-12	BY: RAS	DATE: 09/13/2012	EST. WEIGHT: N/A

